

PIPER

31-350 CHIEFTAIN

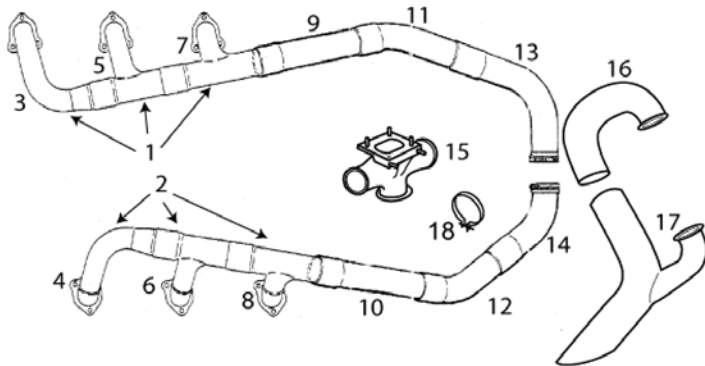

AD 82-16-05 R1 100 hr. repeditive inspection w/dye penetrant or 10 power magnifying glass of upper tailpipe and turbo flanges.

Check transition for cracks

Check stack assemblies for slip joint movement and heat distortion

Check tail pipes for pitting and wall thickness

ITEM	OEM PART NO	DESCRIPTION	Condition
01	LW16825	RH STACK ASSY	OH
02	LW16826	LH STACK ASSY	OH
03	LW10159	RH FRONT RISER	OH
04	LW10164	LH FRONT RISER	OH
05	LW10160	RH CENTER RISER	OH
06	LW10163	LH CENTER RISER	OH
07	LW10161	RH REAR RISER	OH
08	LW10162	LH REAR RISER	OH
09	LW15849	RF INTERMED TUBE 350	NEW
10	LW15849	LF INTERMED TUBE 350	NEW
11	LW16621	RC INTERMED ELBOW 350	NEW
12	LW16696	LC INTERMED ELBOW 350	NEW
13	LW16620	RR INTERMED ELBOW 350	NEW
14	LW16697	LR INTEMED ELBOW 350	NEW
15	LW12437	TRANSITION	OH
16	40310-10	UPPER TAIL PIPE 350	OH
17	40310-09	LOWER TAILPIPE	OH
18	24502-225	CLAMP	NEW
NS	15486	GASKET	NEW
NS	17189-225	BYPASS GASKET	NEW
NS	24096-225	ELBOW GASKET	NEW