

**CESSNA
404 TITAN**

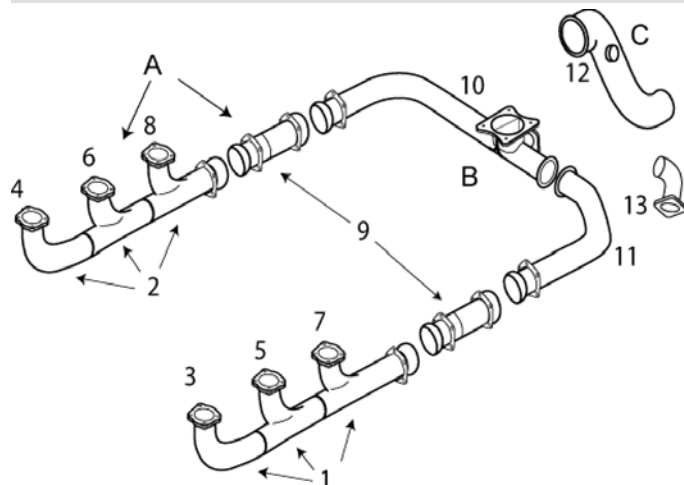

Subject to AD 2000-01-16

AWI is authorized by the FAA to meet the overhaul requirements (paragraph "G") on AD 2000-01-16.

- Visual inspection every 50 hrs. or 30 days
- Remove tailpipes inspect for cracks every 12 mo.
- Inspect & pressure test exhaust system every 12 mo.
- Replace multi-segment V-band clamps every 500 hrs.
- Remove the exhaust system from the slip joints aft to all turbo charger components every 2,500 hrs. or 12 yrs. which ever occurs first.

Pay special attention to:

- A Inspect all slip joints for movement
- B Check flow divider plate for cracks or distortion
- C Check tailpipe for internal pitting and wall thickness

ITEM	OEM PART NO	DESCRIPTION	Condition
01	9910295-13	LH STACK	OH
02	9910295-14	RH STACK	OH
03	9910295-17	LH FWD RISER	OH
04	9910295-18	RH FWD RISER	OH
05	9910295-19	LH CTR RISER	OH
06	9910295-20	RH CTR RISER	OH
07	9910295-21	LH AFT RISER	OH
08	9910295-22	RH AFT RISER	OH
09	A9910296-7	SLIP JOINT S.S.	NEW
10	9910298-12	HEADER	OH
11	9910298-13	ELBOW	OH
12	9910298-1	TAIL PIPE	OH
13	9910298-14	WASTEGATE ELBOW	OH
NS	1001-6	SPRING KIT	NEW